

VerSus International Student Competition

Poster 2: Project and Solutions

Authors: Amandine Chegut, H el ene Defert, Joanna Parker

2

THE CRAFTSMEN STUDIO

Area : 650 m2

Programme : office, locker room, storage, engine room, one regular studio, one large studio, and common kitchen

Cost of works : 650   HT / m2 SHAB



- The studio **tend to gather the craftsmen** of the region to give them more visibility and to allow them **share knowledge**.
- The studio is built with **a youth work training programme** framed by a local training center. These training sites are a great time of conviviality and give the opportunity to complete the formation of apprentices.
- The training site makes use of **local materials** and **materials from recycling**. The studio is **settled in two phases** in order to allow a rapid opening and collect materials.

THE ARTISTS' STUDIO

Energetic consumption : 73 kwh EP/m2 SHON.an

Cost of works : 900   HT / m2

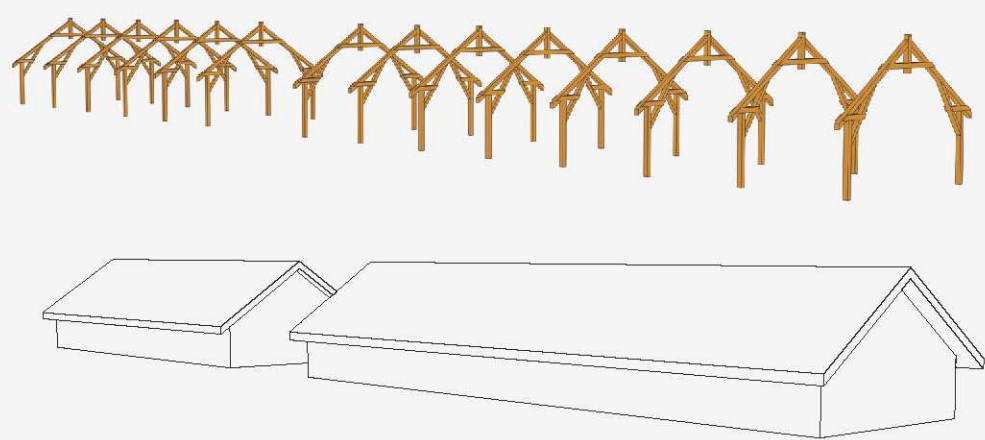

- **Constructive memory** : the life of building is **extended by preservation of the wood structure**. A more efficient envelope that contains the volume of origin is implemented.
- **To stimulate the creativity** : inside the studio, the **finishing touch** are done **by the artists** themselves and **the exterior walls** have different colors depending on the coated earth experimentation.

TEMPORARY ACCOMMODATION

Area : 400 m2

Programme : 2 studios, 10 two-bedroom flats, 3 common spaces

Energetic consumption : 73 kwh EP/m2 SHON.an

Cost of works : 1300   HT / m2

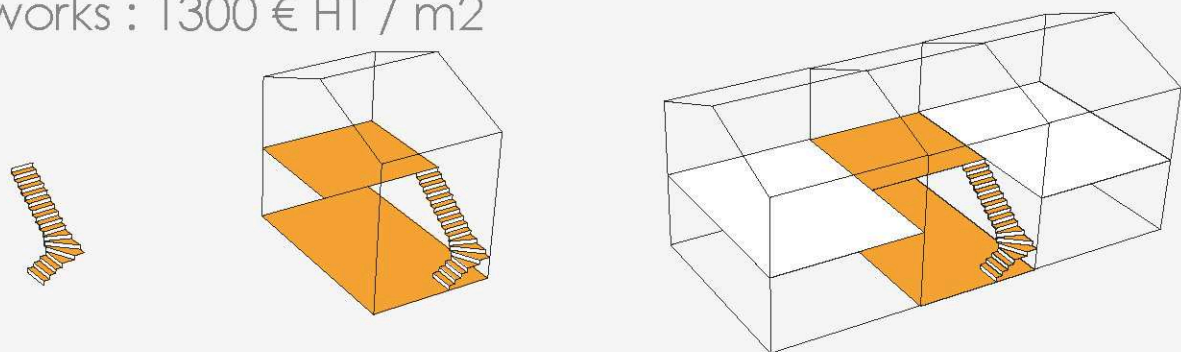

- **Community sharing** : there are **spacious common areas largely open on the outside**, that encourages **the meeting of apprentices**.
- **Learning from vernacular** : **inspired from the local sawmill**, the Buildings have a **vertical wooden cladding** that slow down the aging of the wood.
- **Unchanged morphology** : the heights are similar to the surrounding houses in order to create **a global consistency**.
- **To contribute to health quality** : the orientation **maximizes solar gain** during winter (pick up and retransmits energy with **earth walls**). These walls **regulate humidity**.
- **Community sharing** : there are **spacious common areas largely open on the outside**, that encourages **the meeting of apprentices**.

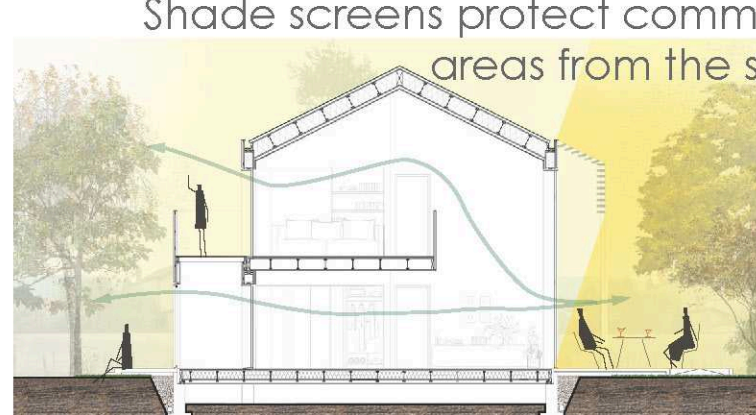
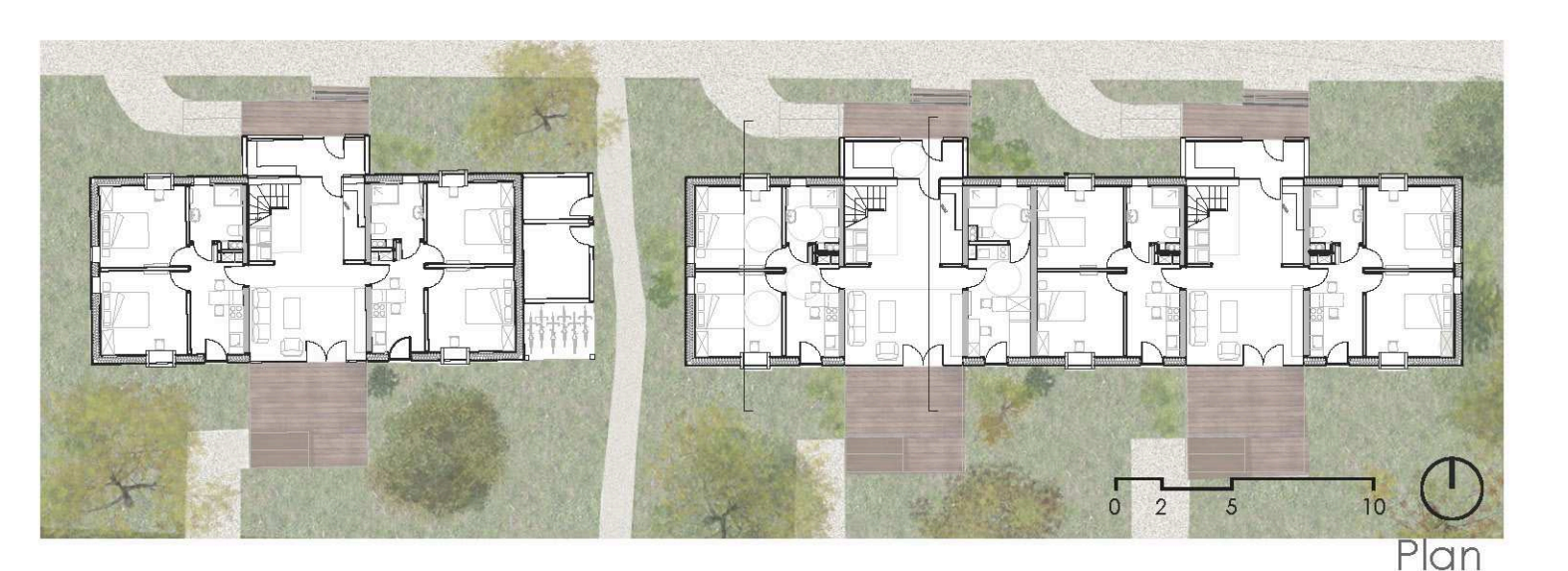
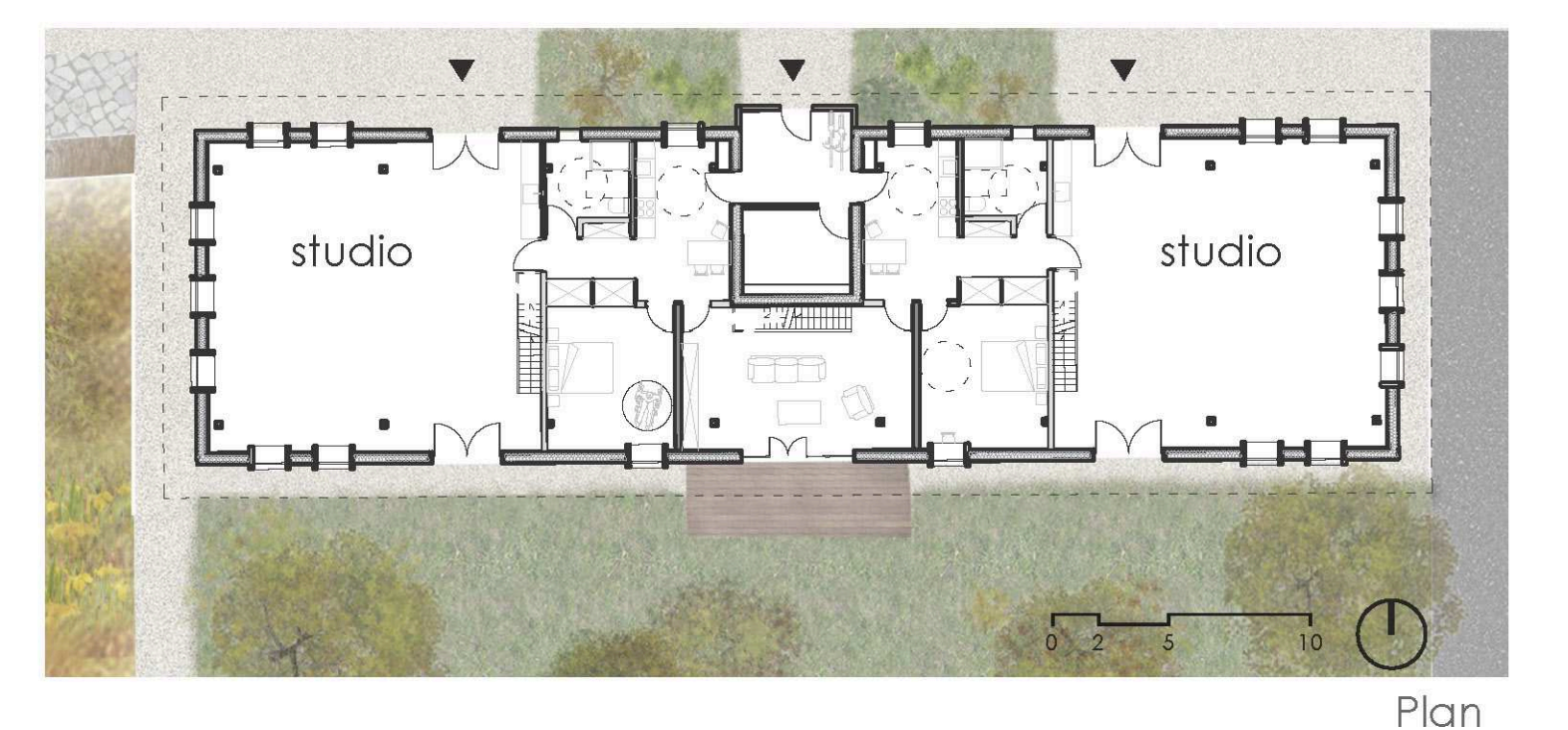
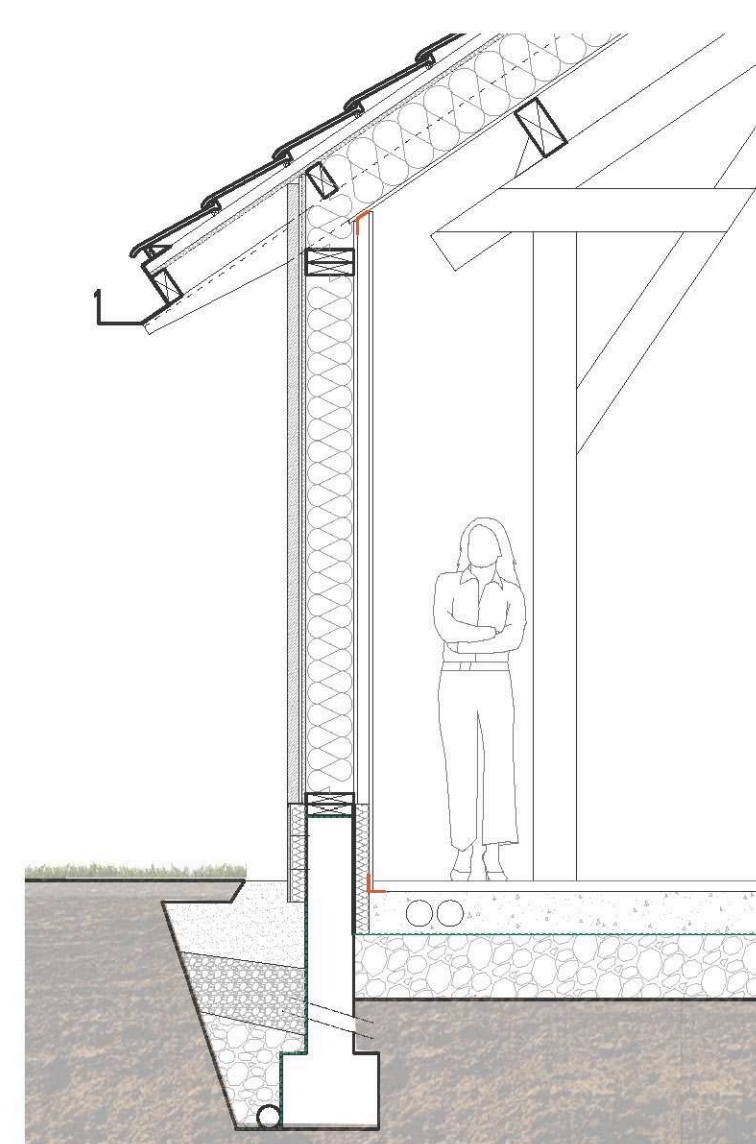
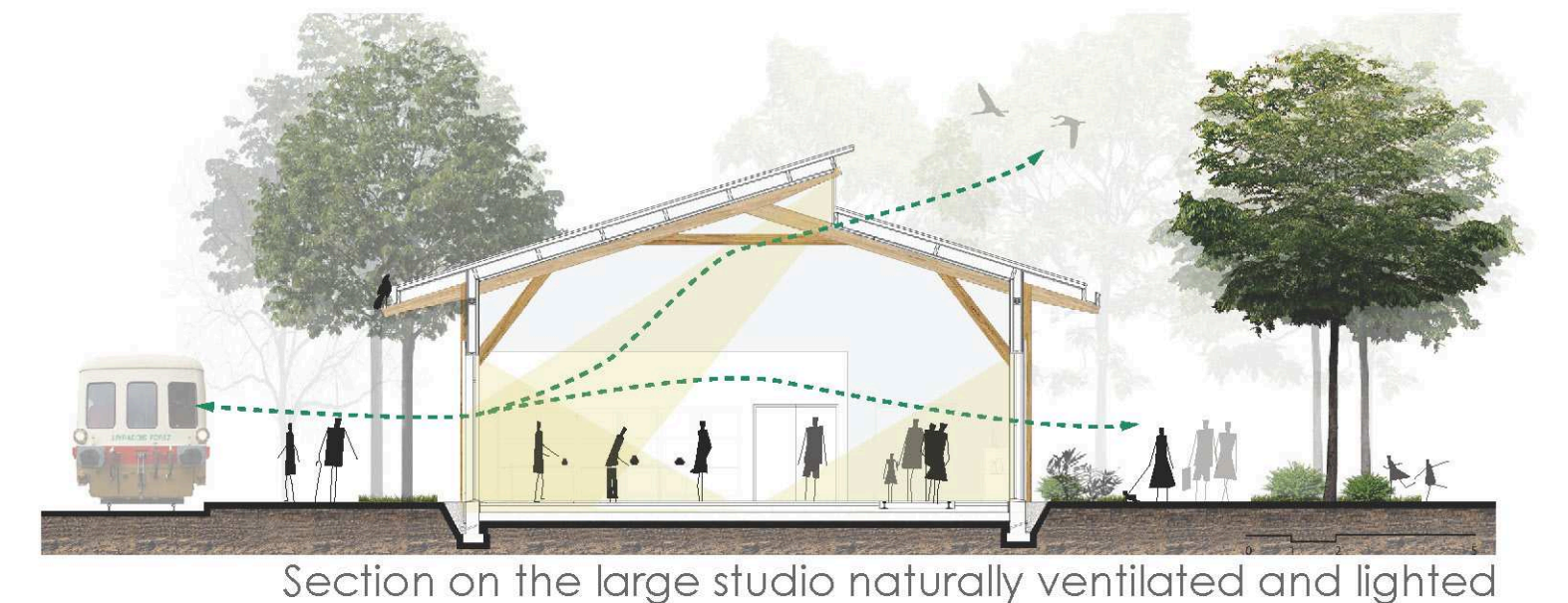
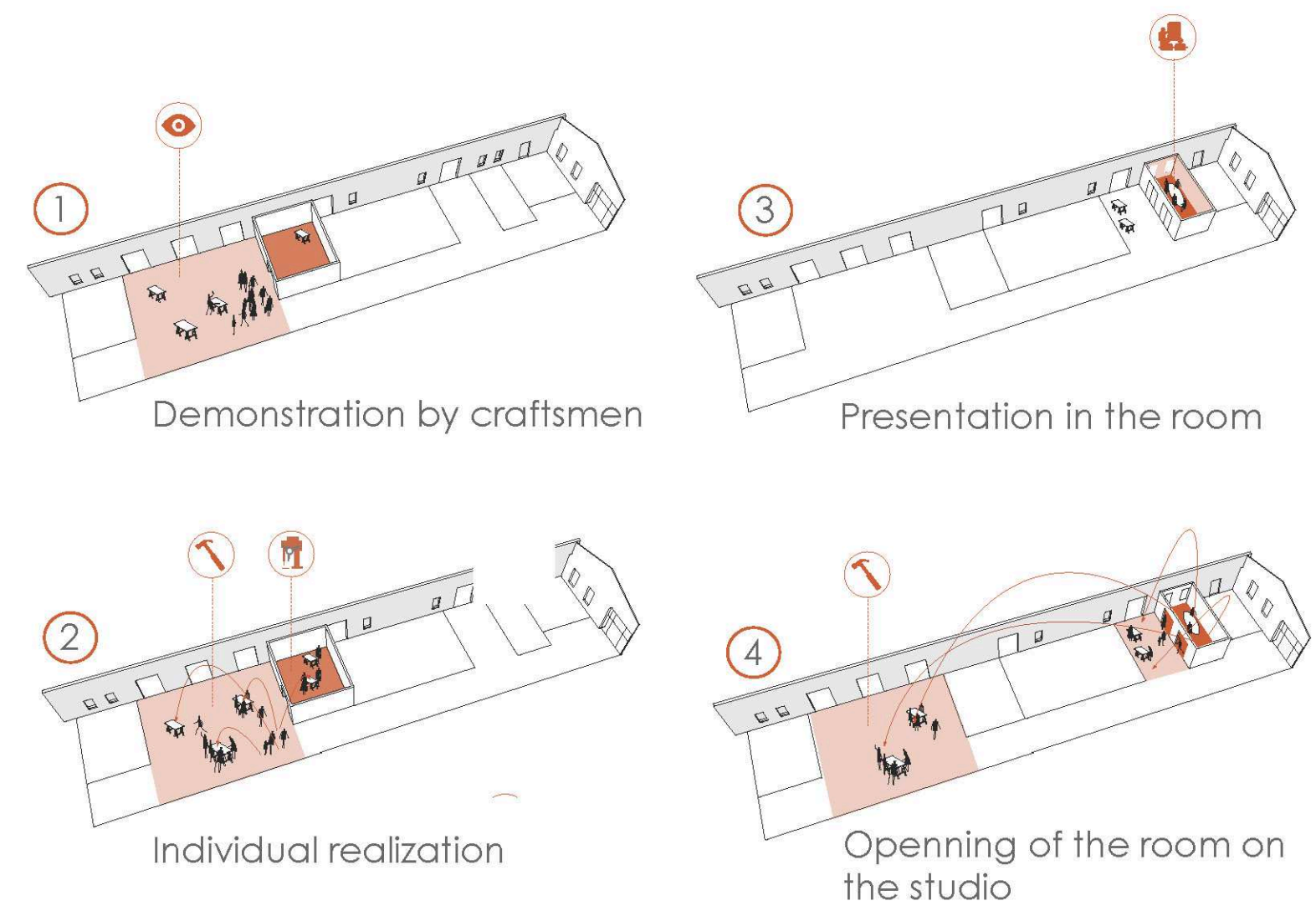
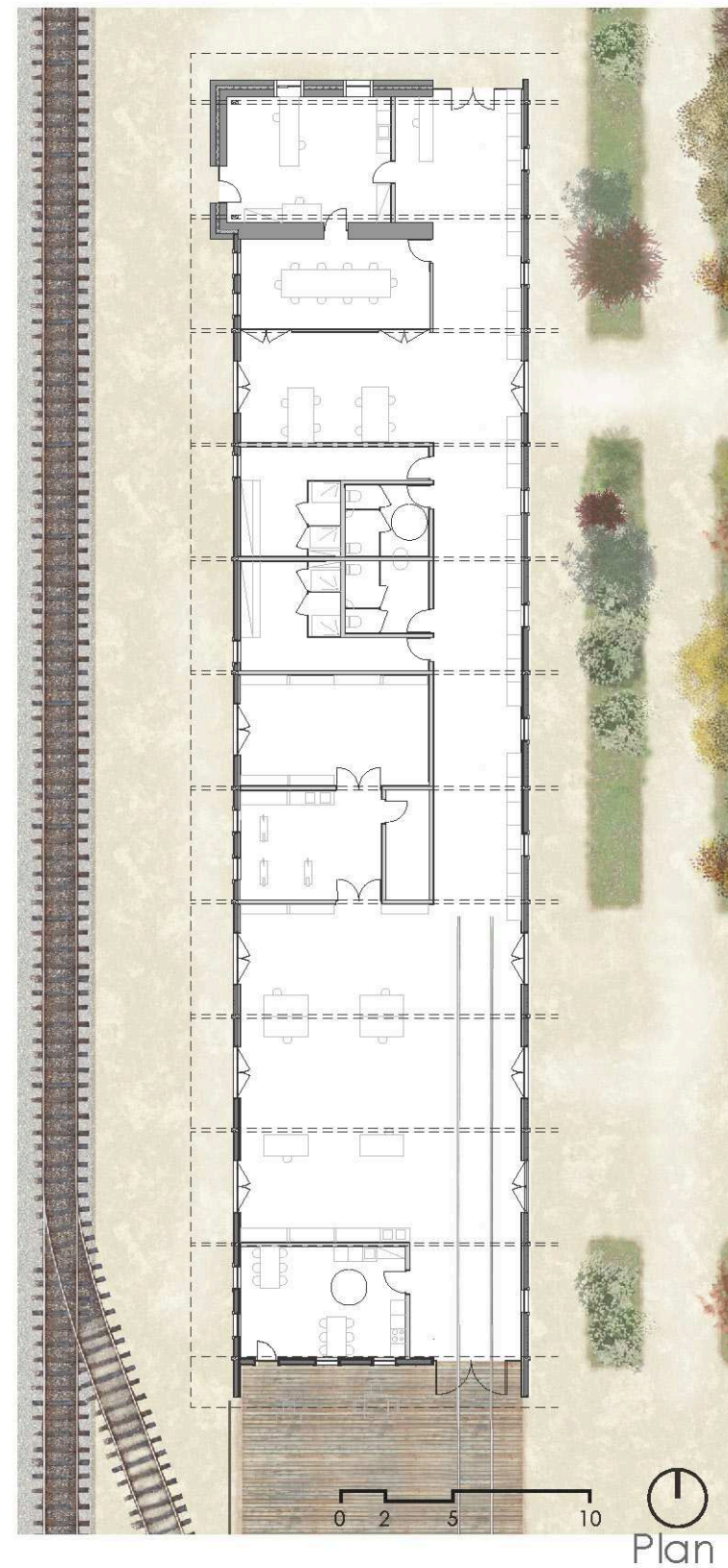

Project Leader



Partners



With the support of the Culture Programme of the European Union

